

Applications

- ▶ Motorsport
- ▶ Marine
- ▶ Telematics
- ▶ Data-logging

Features

- ▶ High Performance 10Hz GPS Receiver
- ▶ CAN Bus Output of Position, Velocity & Time
- ▶ User Configurable Analogue Output
- ▶ User Configurable Digital Output
- ▶ Virtual Lap Beacon Output
- ▶ RS232 Serial Output of NMEA, position velocity and time.

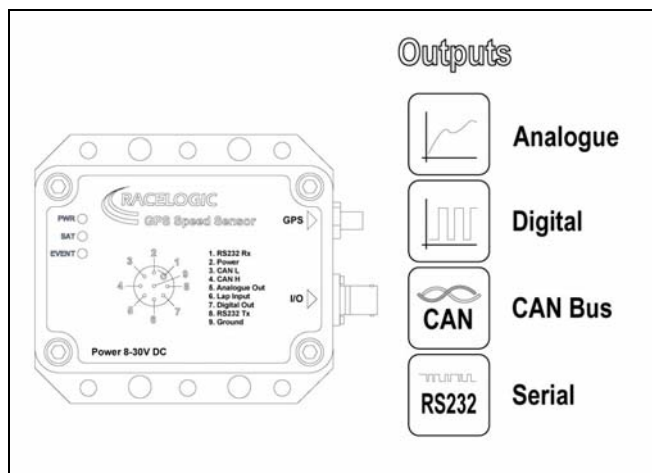

The VB10SPS is a non-contact speed and position sensor based on GPS technology. Data output is via CAN Bus to allow easy integration into most motor sport and testing applications.

The VB10SPS also features analogue and digital outputs. The analogue output corresponds to either vehicle speed, lateral acceleration, longitudinal acceleration, or lap beacon marker with user selectable scaling. The digital output can be configured as either a digital speed pulse output or a lap beacon marker.

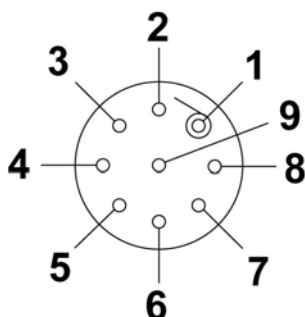

- 1 RS232 Rx (Receive Data)
- 2 Power In (8v to 30v DC)
- 3 CAN Bus Low
- 4 CAN Bus High
- 5 Analog Output
- 6 Lap Marker Input
- 7 Digital Output
- 8 RS232 Tx (Data Output)
- 9 Ground



Non-Contact Speed Sensor VB10SPS

GPS			
Velocity		Distance	
Accuracy	0.2 Km/h	Accuracy	0.05% (<50 cm per Km)
Units	Km/h or Mph	Units	Metres / Feet
Update rate	10 Hz	Update rate	10 Hz
Maximum velocity	1000 Mph	Resolution	1 cm
Minimum velocity	0.1 Km/h	Height accuracy	10 Metres 95% CEP**
Resolution	0.01 Km/h		
Absolute Positioning		Time	
Accuracy	2.5m 95% CEP**	Resolution	0.1 s
Update rate	10 Hz	Accuracy	0.1 s
Resolution	1 cm		
Heading		Acceleration	
Resolution	0.01°	Accuracy	1%
Accuracy	0.2°	Maximum	4 G
		Resolution	0.01 G
		Update rate	10Hz
Definitions			
** CEP = Circle of Error Probable			
95% CEP (Circle Error Probable) means 95% of the time the position readings will fall within a circle of the stated diameter			

Outputs	
CAN Bus	
Output Data Rate	125Kbit, 250KBit, 500KBit, 1MBit selectable. Un-terminated CAN node.
Data Available	Position, vehicle speed, Heading, Lateral Acceleration, Longitudinal Acceleration, Satellite Count, Time, Radius of Turn, Roll Angle Estimate, Altitude
RS232	
Output Data Rate	10Hz
Data Available	NMEA \$GPGGA and \$GPVTG messages at 115200Baud
Analogue Output	
Output Data Rate	0v to 5v DC
Data Available	Any one of Speed, Lateral Acceleration, Longitudinal Acceleration, Roll angle (Motorcycle only), or Lap Beacon
Digital Output	
Output Data Rate	Low = 0v, High = 5v

Inputs	
Power	8v to 30vDC 1.5W Max
GPS Antenna	3V Active Antenna (inc)
Digital Input	Cold Start Activate / Set Lap Beacon Position
LED	Power, Satellite Count, Event Out

Environmental and Physical	
Size	Approx 90mm x 92mm x 28mm, not including connectors
Weight	Approx 200g
Connectors	Deutsch Autosport
IP Rating	IP66